

Dimension: (Unit: mm)

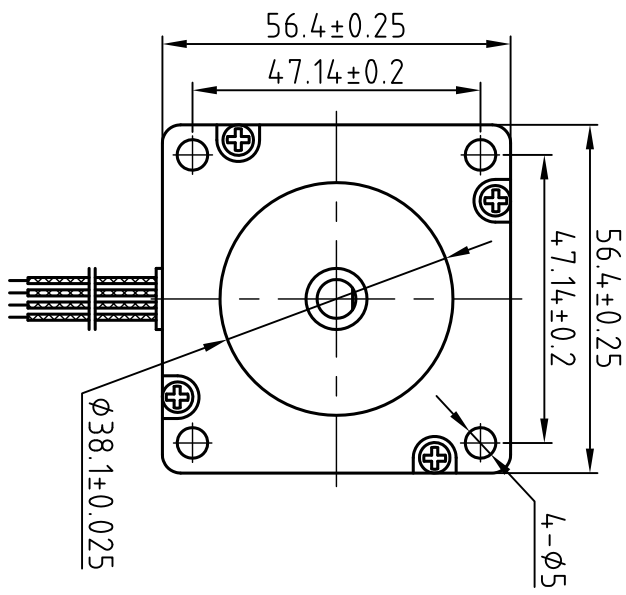

Motor Connections:

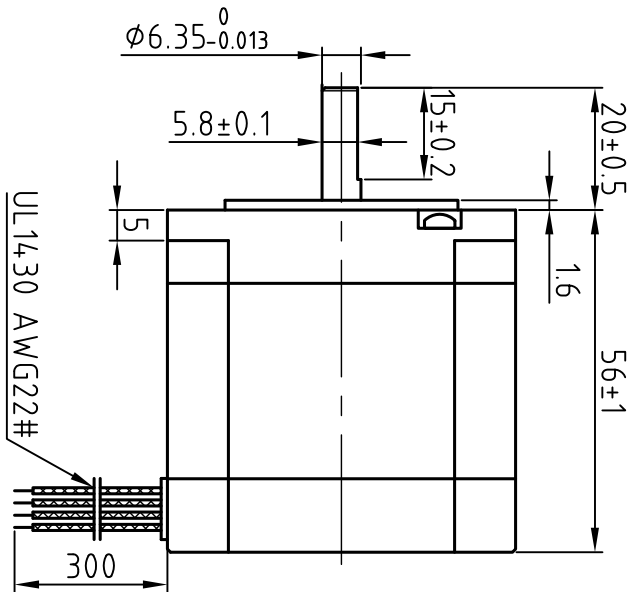
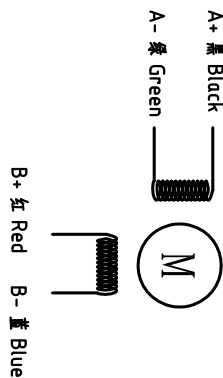

Common Rating

Step angle	1.8°
Position accuracy	1.8±0.09°
Dielectric strength	500VAC 1min
Insulation resistance	100MΩhm(500VDC)
Insulation class	B
Temp rise(Max)	80K
Radial play	Max:0.02mm(load 4.50g)
Axial play	Max:0.08mm(load 900g)

Specification:

Current/phase	4.0 A
Voltage	5.0 V
DC Resistance/phase ±10%	0.42 Ω
Inductance/phase ±20%	1.4 mH
Holding torque	1.3 N·M
Inertia	0.3 kg·cm ²
Weight	0.7 kg

设计 Designed	日期 Date	材料 Material	深圳市雷赛智能控制股份有限公司 SHENZHEN LEADSHINE TECHNOLOGY CO., LTD.
审核 Checked		第一角画法 First angle projection	名称 Title
批准 Approved		重量/比例 Weight/Scale	混合式步进电机
图号 Part No.		共 1 套 第 1 套 Sheet 1 of 1	图号 DWG. NO.
			57HS13B

版本 Rev	日期 Date	变更文件号 ECR NO.	变更内容 Revisions	设计 By